

REV.	DESCRIPTION	DATE	BY

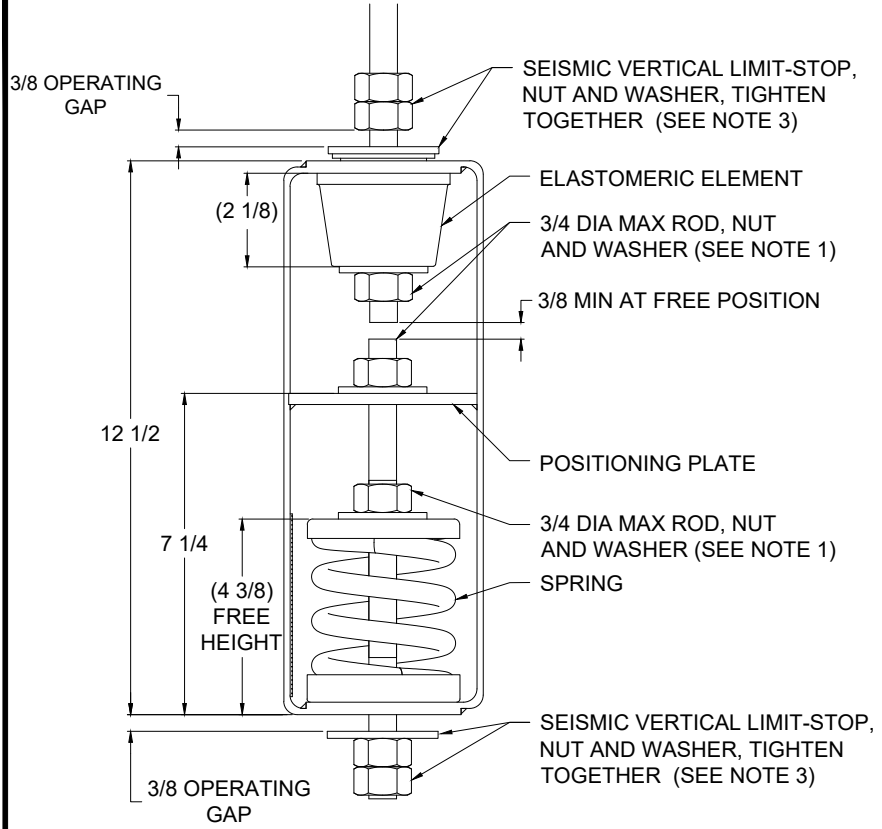

TYPE HRSP-1E ELASTOMERIC & SPRING POSITIONING FOR 1" NOMINAL DEFLECTION					
HANGER	RATED LOAD (LBS)	DEFLECTION (IN)	SPRING RATE (LB/IN)	SPRING COLOR CODE	ELEMENT LOAD & COLOR CODE
HRSP-1E-195	195	2.21	100	DK BLUE	RE-C-380 BLACK
HRSP-1E-400	400	1.70	303	BLACK	RE-C-520 RED
HRSP-1E-530N <sup>1</sup>	530	1.49	453	BLACK/ DK BLUE	RE-C-840 GREEN
HRSP-1E-650	650	1.44	619	RED	RE-C-840 GREEN
HRSP-1E-825N <sup>1</sup>	825	1.56	771	RED/ DK BLUE	RE-C-840 GREEN
HRSP-1E-1000	1000	1.47	1000	TAN	RE-C-1070 GRAY
HRSP-1E-1200N <sup>1</sup>	1200	1.34	1154	TAN/ DK BLUE	RE-C-2000 BLUE
HRSP-1E-1400	1400	1.35	1400	PINK	RE-C-2000 BLUE
HRSP-1E-1700N <sup>1</sup>	1700	1.53	1545	PINK/ DK BLUE	RE-C-2000 BLUE
HRSP-1E-2000	2000	1.61	1802	WHITE	RE-C-2000 BLUE

**NOTES:**

1. TWO NESTED SPRINGS YIELD THIS LOAD. THE COLOR CODE IS FOR OUTER SPRING/ INNER SPRING.

**NOTES:**

- HANGER RODS, NUTS AND WASHERS, AS SHOWN, NOT BY THE VMC GROUP.
- STANDARD FINISH: HANGER BOX - PAINTED, POWDER COATED OR GALVANIZED STEEL, SPRING - POWDER COAT.
- SEISMIC VERTICAL LIMIT-STOP REQUIRED FOR SEISMIC APPLICATIONS. NOT BY THE VMC GROUP. INSTALL WASHER .16 THK. MIN. X 2-1/2 O.D. MIN WITH REQUIRED INSIDE DIAMETER TO ACCOMMODATE ROD SIZE IN USE. THIS CAN BE ACCOMPLISHED BY USING A SINGLE WASHER OR BY STACKING NOT MORE THAN TWO WASHERS.
- ALL DIMENSIONS IN INCHES. INTERPRET PER ANSI Y14.
- ALL DIMENSIONS ARE FOR REFERENCE, DIMENSIONS SHOWN AS NOMINAL.
- ALL SPRINGS ARE DESIGNED WITH MINIMUM 50% OVER-TRAVEL.
- HANGER BOXES WITH AN ELASTOMERIC ELEMENT HAVE UP TO AN ADDITIONAL 1/2" NOMINAL DEFLECTION.
- RATED DEFLECTIONS ARE WITHIN 25% OF NOMINAL. HIGHER DEFLECTIONS ARE ALLOWED IF THEY MEET SPECIFICATIONS.

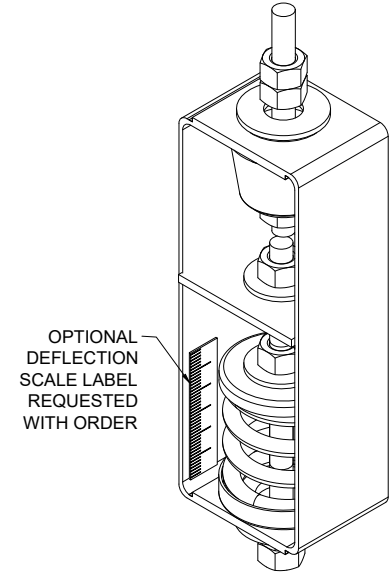

OTHER MATERIALS, COMPOUNDS, OR FINISHES WITH EQUAL OR SUPERIOR PROPERTIES MAY BE SUBSTITUTED AS THEY BECOME AVAILABLE.

**CERTIFIED FOR:**

JOB NAME: \_\_\_\_\_

CUSTOMER: \_\_\_\_\_

CUSTOMER P.O.: \_\_\_\_\_

SALES ORDER: \_\_\_\_\_

MODEL HRSP-1E 195-2000 LBS.  
ELASTOMERIC AND SPRING  
POSITIONING HANGERS  
1 INCH DEFLECTION

**VMC GROUP**  
THE POWER OF TOGETHER  
Bloomingtondale, NJ 07403  
Houston, TX 77041

SCALE:	NONE	
SHEET:	1	
DRAWING NO.:		REVISION